

Dual-Wire Dual-Operator Programmable Monitor Installation, Operation, and Maintenance

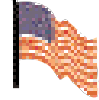

Made in America

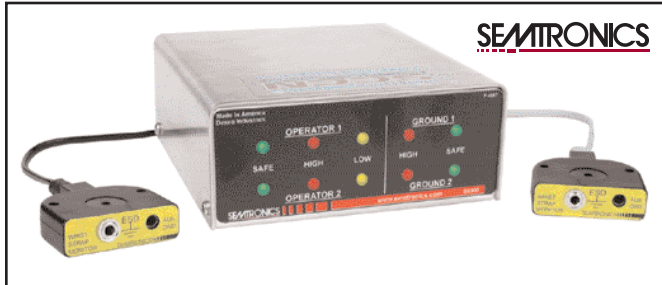

Figure 1. Dual-Wire Dual-Operator Programmable Monitor

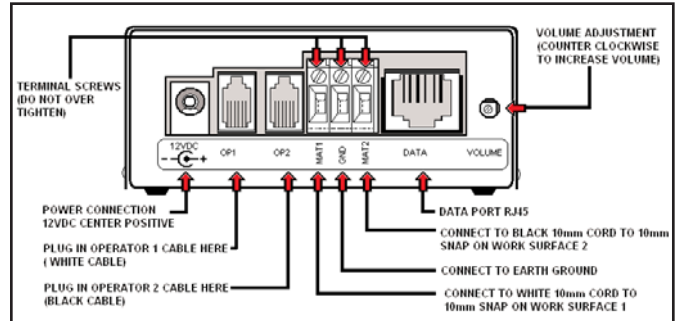

Figure 2. 62030 Rear View

Description

Continuous monitors pay for themselves, by improving quality, productivity, and eliminating daily wrist strap testing and test result logging. Per ESD-S1.1 paragraph 6.1.3 Frequency of Functional Testing, "The wrist strap system should be tested daily to ensure proper electrical value. Daily testing may be omitted if constant monitoring is used."

Per ESD Handbook TR20.20 paragraph 5.3.2.4.4, "Typical test programs recommend that wrist straps that are used daily should be tested daily. However, if the products that are being produced are of such value that knowledge of a continuous, reliable ground is needed, and then continuous monitoring should be considered or even required."

The Semtronics 62030 Dual-Wire Dual-Operator Programmable Monitor can maintain two work surfaces and two operators at ground potential to virtually eliminate the risk of ESD damage. The highly visible LED display and audible alarm makes it easy to monitor the status of the work surfaces and operators. The 62030 Dual-Wire Dual-Operator Programmable Monitor uses Semtronics patented* dual resistive loop technology. No other method is as direct and reliable. Both work surfaces, and individual operator resistance limits, can be programmed and re-configured as required. If the ground potential of either work surface or operator is lost the 62030 immediately alarms (both audible and visual). The 62030 is unaffected by capacitance variations associated with personnel and environmental conditions.

The 62030 Dual-Wire Dual-Operator Programmable Monitor features:

- Monitoring of two operators independently.
- Monitoring of two ground connections (work surfaces) independently.
- Fully independent alarming conditions: audible and visual.
- Independent LED status lights for each operator and each ground connection (work surface.)
- Two independent operator wrist strap ground point remotes with 10' cables.

*U.S. Patents 6,052,053 and 6,205,408

Installation

Remove the monitor from its packaging and inspect for any shipping damage. Included with each 62030 Dual-Wire Dual-Operator Programmable Monitor should be:

- | | |
|-------------------------|-----------------------------|
| 1 Monitor | 1 Hardware Kit (62012) |
| 1 White Operator Remote | 3 Grounding Wires (SE-5136) |
| 1 Black Operator Remote | 1 Mat Ground Cord (Grey) |
| 1 AC Adapter | 1 Mat Ground Cord (Black) |
| 4 Push Clinch Snaps | |

- Determine the mounting location of the 62030 monitor. The front panel should be visible to a supervisor.
- Determine the mounting location of the operator remotes. The white remote is for operator #1 and the black remote is for operator #2. Make sure that each remote is located so that the remote leads reach the monitor but are convenient for the operator.
- Attach the operator remotes to the bench or other surface using the provided screws.
- Attach the tinned wire ends of the mat wires to the appropriate screw terminal connection on the rear of the unit. (See Figure 2). The white wire is for operator #1 and the black wire is for operator #2.
- If not already done, attach the work surface to workstation common point ground using the pictured ground wires. For mats, attach the grounding point snaps at the ends of the ground monitor cords to the grounding point snaps on the work surface. These ground monitor cords are used for sensing whether or not the unit is properly grounded. Refer to figure 3 for snap-plate fitting diagram and for laminates or other hard surfaces with a buried conductive layer.
- Attach the tinned wire end of the black ground-reference wire to the center position of the screw terminal block on the rear of the unit. Attach the ring terminal end to an alternate ground point. It is important that this ground wire is attached to a separate ground point other than the work surface ground

cords from the previous step to ensure proper independent monitoring. The faceplate screw of a grounded AC wall outlet may provide a convenient connection point.

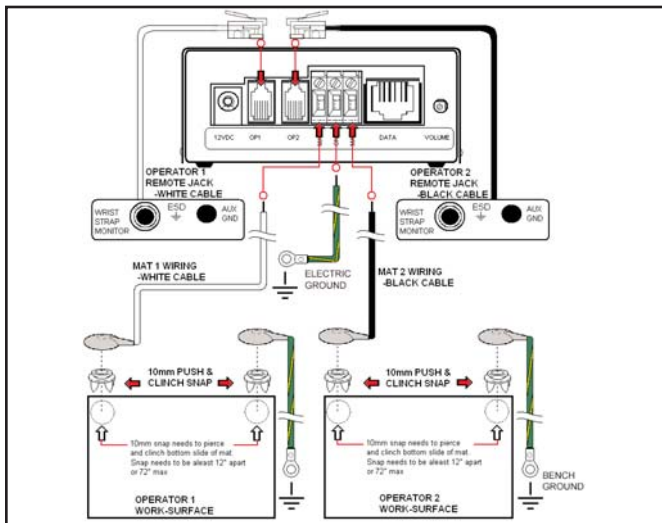

Figure 3. Mat Grounding

G. Route the work surface monitor wires from the back of the monitor unit, to the snaps/bolts attached to the grounded surfaces. Attach the white ground wire to the operator #1 work surface and the black ground wire to the operator #2 work surface.

H. Route the operator remote wires to the monitoring unit and insert the modular plugs into the appropriate jacks on the rear of the unit. (See Figure 2)

Mat Grounding

It is recommended to connect the mat wire (10mm snap) from the monitor and the mat ground wire (10mm snap) to two separate points on the bench mat as in Figure 4.

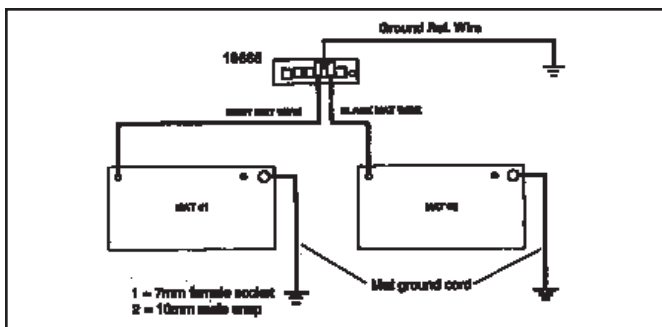

Figure 4. Mat Grounding

I. If using a TR2000 SmartHub along with the 62030, construct a data output cable. Refer to Figure 5.

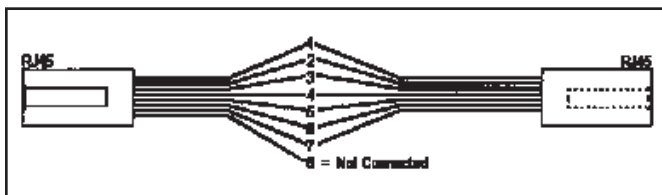

Figure 5. Data Cable

J. Plug the DC power supply plug into the power jack in the rear of the unit. Route the wire from the supply to a nearby AC outlet and plug the power supply into the outlet. Make sure the voltage and frequency match those listed on the AC adapter. The monitor should now be powered.

Operation

Wrist Strap Connections

Once all the connections described above have been made and the unit has been powered up, the unit is ready for operation. Install operator wrist straps and ground wires. Dual snaps on the operator ground wires attach to the wristband snaps and the mono plug on the other end inserts into the operator remote as illustrated in Figure 6. The operator's monitoring is in "STANDBY" mode until the operator's ground wire is plugged into the remote jack for that station.

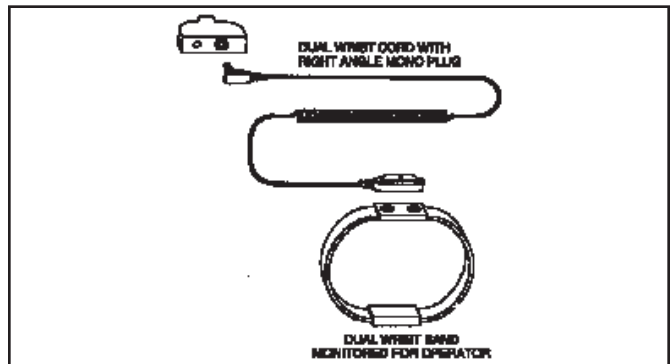

Figure 6. Operator Ground Cords and Wrist Snaps

NOTE: The operator remote has two jacks. One is a 3.5 mm mono jack for use with a dual wrist strap. A dual operator ground wire plugged into this jack will be monitored. The other jack is a grounded banana jack for use with a single conductor operator ground wire. This is a grounded guest hook-up that is not monitored.

Status Indicators

The audible alarm for Operator 1 and Ground 1 is continuous. The audible alarm for Operator 2 and Ground 2 is a repetitive beep. If a fault condition exists for both operators and/or both grounds, the alarm will sound continuously. The alarm volume may be adjusted with the potentiometer on the rear of the unit. Refer to Figure 7.

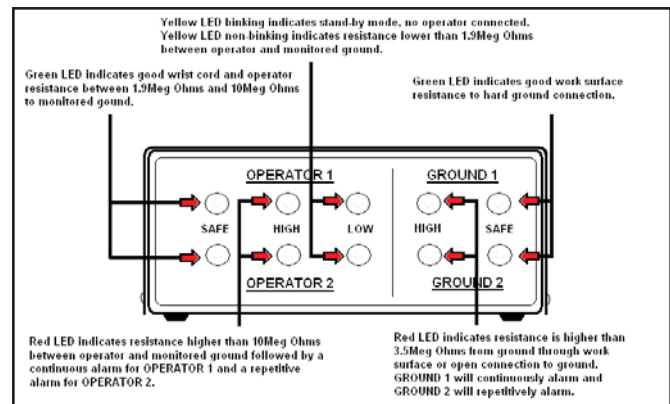

Figure 7. Status Indicator

The 62030 provide status indicators for the following conditions:

- **Standby** - The operator is not plugged into the remote. This condition is indicated by a flashing yellow LED in the operator section of the display.
 - **Operator Fail High** - The operator's series resistance is greater than the upper resistance limit. This condition is indicated by the red LED in the Operator section of the display along with an audible alarm
 - **Operator Fail Low** - The operator's series resistance is less than 1.9Meg Ohm. This condition is indicated by the flashing yellow LED in the Operator section of the display.
 - **Operator Pass/Safe** - The operator's series resistance is within the range of 1.9Meg Ohm to the upper resistance limit. This condition is indicated by the green LED in the Operator section of the display.
 - **Ground Fail High** - The resistance from the mat connection to ground is greater than 3.5Meg Ohm. This condition is indicated by the red LED in the Ground section of the display as well as an audible alarm.
 - **Ground Pass Safe** - The resistance from the mat connection to ground is less than 3.5Meg Ohm. This condition is indicated by the green LED in the Ground section of the display.
- The resistance values quoted above are the Factory Defaults. These numbers will vary depending on the configuration.

Changing the Test Voltage

The 62030 can be set for a test voltage of either +5V or +8V. Reducing the test voltage will result in a lower finger-tip voltage on the operator. To change the test voltage you must set two jumpers inside the unit.

Remove the four case screws and open the 6110 case. BE SURE TO OBSERVE ESD PRECAUTIONS, AS THERE ARE ESD SENSITIVE DEVICES INSIDE THE CASE. Refer to Figure 8 for setting the test voltage to +5V and +8V.

Specifications

- Two user selectable resistance levels of 10 Meg ohms or 35 Meg ohms.
- Two user selectable test voltage settings of +5V or +8V.
- SCCN compatible data output.
- Stainless Steel housing.
- Size: 4.3" W x 4.4" D x 1.8" H
- Plug-in power supply: 110 VAC/60Hz input, 12VDC/500mA output or 230VAC/50Hz input, 12VDC/500mA output. 2.5mm connector - center positive. Any alternate transformer must comply with the Safety Extra Low Voltage (SELV) insulation requirements.
- Important: This appliance has a metal casing but the earth connection is only used for operational purposes. It is considered to be class I and tested as class II. The power supply connection plug is accessible to the user and there is no safety insulation inside the Semtronics Item #62030. Therefore the insulation of the power supply is critical.
- Rated Power consumption: 3.6VA.

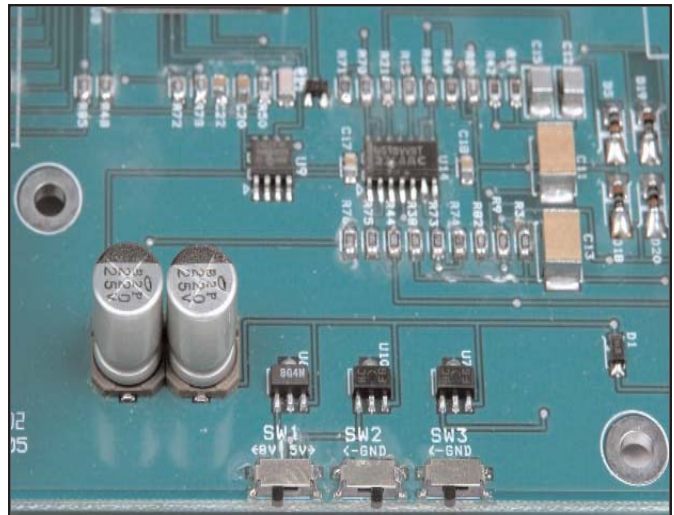

		Dip Switches	
Function		Down	Up
Switch 1	Input Voltage	8v	5v
Switch 2		5v	8v
Switch 3	Wrist Strap High limit	35m	10m

Figure 8. Jumper Setting for various test voltages

Environmental Conditions

- Suitable for indoor use only at altitudes not exceeding 6500ft. (2Km)
- Maximum relative humidity of 80% up to 88°F (31°C) decreasing linearly to 50% @ 104°F (40°C)
- Pollution degree 2 per IEC 644
- Temperature range of 41°F (5°C) to 104°F (40°C)

Limited Warranty

ESD Systems.com expressly warrants that for a period of one (1) year from the date of purchase, Semtronics Dual-Operator Programmable Monitor will be free of defects in material (parts) and workmanship (labor). Within the warranty period, the product will be tested, repaired, or replaced at our option, free of charge. Call our Customer Service Department at 508-485-7390 (Marlboro, MA) for a Return Material Authorization (RMA) and proper shipping instructions and address. Include a copy of your original packing slip, invoice, or other proof of purchase date. Any unit under warranty should be shipped prepaid to the ESD Systems.com factory. Warranty repairs will take approximately two weeks.

If your unit is out of warranty, call Customer Service at 508-485-7390 (Marlboro, MA) for a Return Material Authorization (RMA) and proper shipping instructions and address. ESD Systems.com will quote repair charges necessary to bring your unit up to factory standards.

Warranty Exclusions

THE FOREGOING EXPRESS WARRANTY IS MADE IN LIEU OF ALL OTHER PRODUCT WARRANTIES, EXPRESSED AND IMPLIED, INCLUDING MERCHANTABILITY AND FITNESS FOR A PARTICULAR PURPOSE WHICH ARE SPECIFICALLY DISCLAIMED. The express warranty will not apply to defects or damage due to accidents, neglect, misuse, alterations, operator error, or failure to properly maintain, clean or repair products.

Limit of Liability

In no event will ESD Systems.com or any seller be responsible or liable for any injury, loss or damage, direct or consequential, arising out of the use of or the inability to use the product. Before using, users shall determine the suitability of the product for their intended use, and users assume all risk and liability whatsoever in connection therewith.